

**Peugeot 407 (2004- )  
Peugeot 508 (2011- )  
Citroën C5 (2008- )**

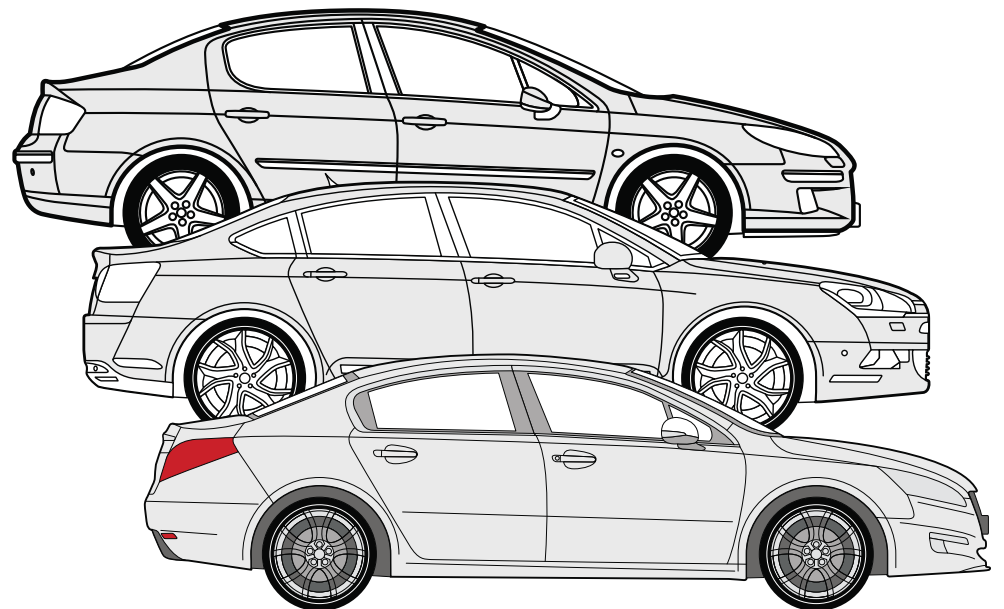



94/20/EC

Peugeot 407 (2004-)  
 Peugeot 508 (2011-)  
 Citroën C5 (2008-)

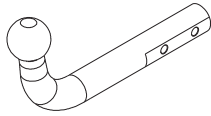

e13	APPROVALNUMBER	D-VALUE
	00-3384	D 10,45 kN
TYPE	CLASS	MAX.VERT.LOAD
PEU030	A50-X	S 85 kg

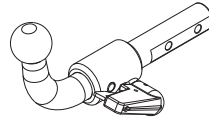

e13	APPROVALNUMBER	D-VALUE
	00-3385	D 10,45 kN
TYPE	CLASS	MAX.VERT.LOAD
PEU031-S	A50-X	S 85 kg

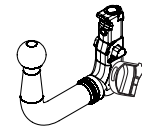

e13	APPROVALNUMBER	D-VALUE
	00-3385	D 10,45 kN
TYPE	CLASS	MAX.VERT.LOAD
PEU031-V	A50-X	S 85 kg

D = 10,45 kN



T = 2000 Kg



S = 85 kg

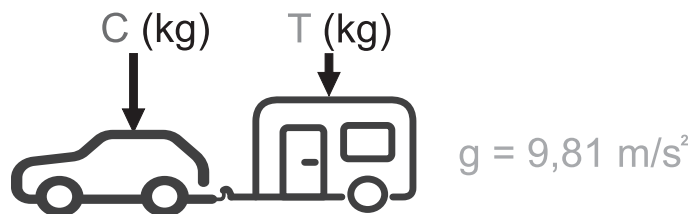
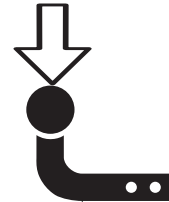







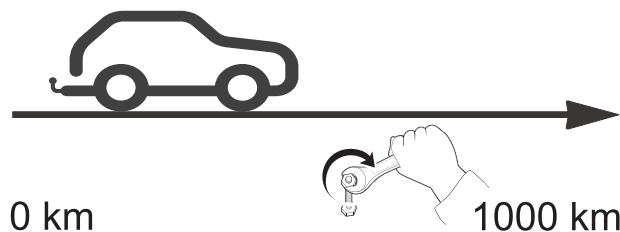

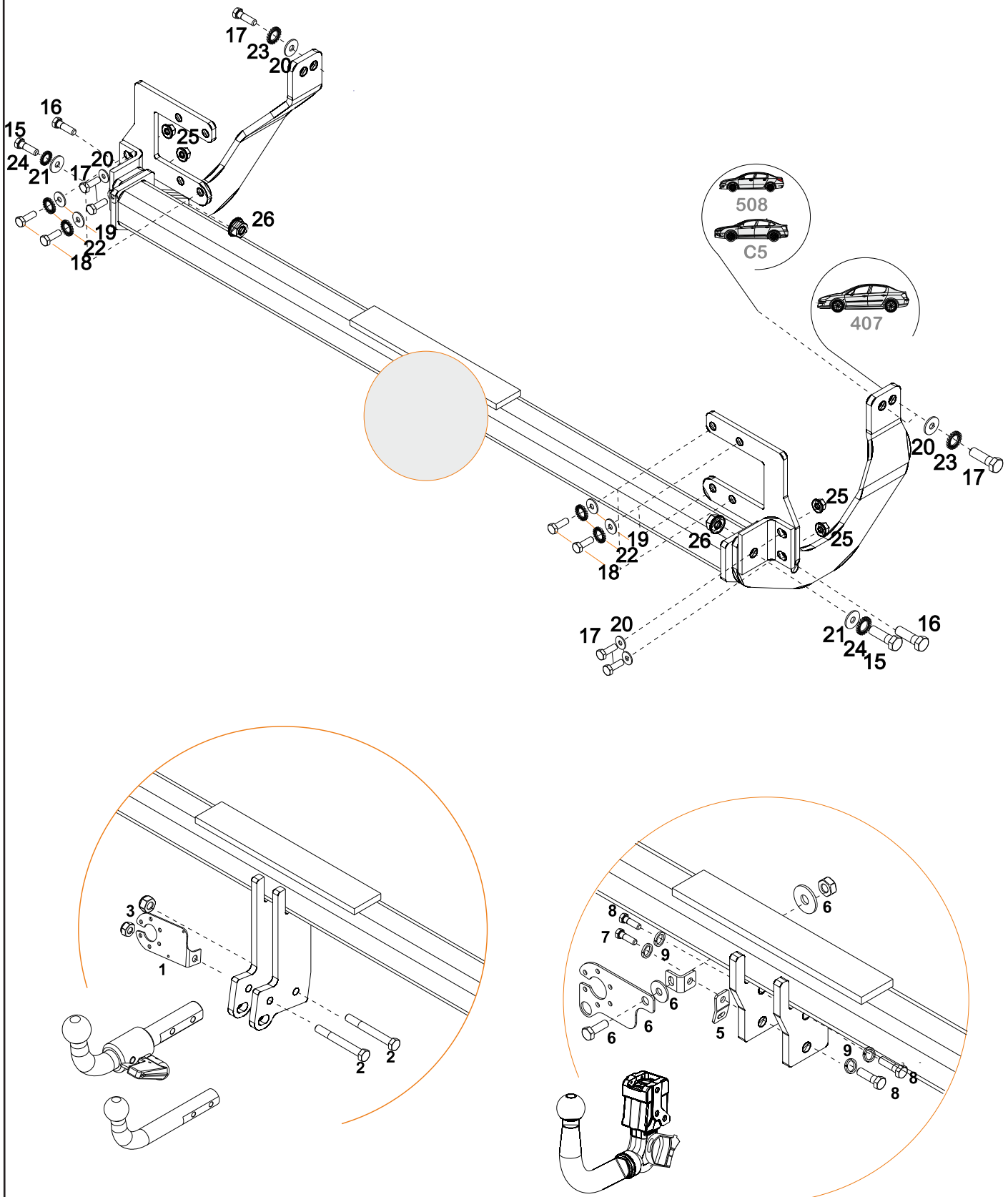

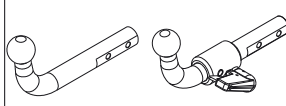
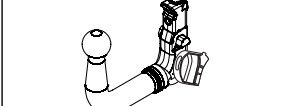
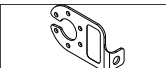
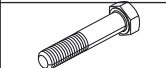

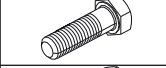
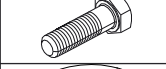
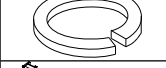
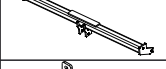
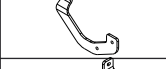
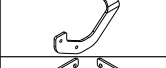

$$D \geq \frac{T \cdot C}{T + C} \cdot \frac{g}{1000} \text{ (kN)}$$

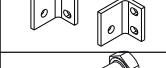
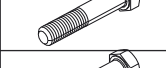
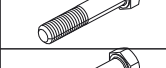
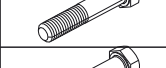
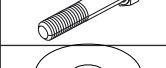
$$T \leq \frac{C \cdot D \cdot 1000}{(C \cdot g) - (1000 \cdot D)} \text{ (kg)}$$

	M8	M10	M12	M14	M16
	N/m	20	40	60	105

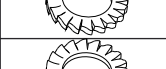

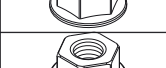

				
1			1	
2		M10x65 DIN 933	2	
3		M10 DIN 980	2	
4			1	1
5				1
6				1
7		M12x35 DIN 933		1
8		M12x25 DIN 933		4
9		Ø12 DIN 128		4
10		C4724A	1	1
11		C4724AA20	1	1
12		C4724AA20	1	1
13		C4724AA22_23	1+1	1+1
14		C4724AA40	1+1	1+1
15		M12x50 DIN 933	2	2
16		M12x40 DIN 933	2	2
17		M10x35 DIN 933	6	6
18		M8x40 DIN 933	8	8
19		Ø8 DIN 9021	8	8
20		Ø10 DIN 9021	6	6
21		Ø12 DIN 9021	2	2
22		Ø8 DIN 6798	8	8
23		Ø10 DIN 6798	2	2
24		Ø12 DIN 6798	2	2
25		M10 DIN 6923	4	4
26		M12 DIN 6923	2	2

1

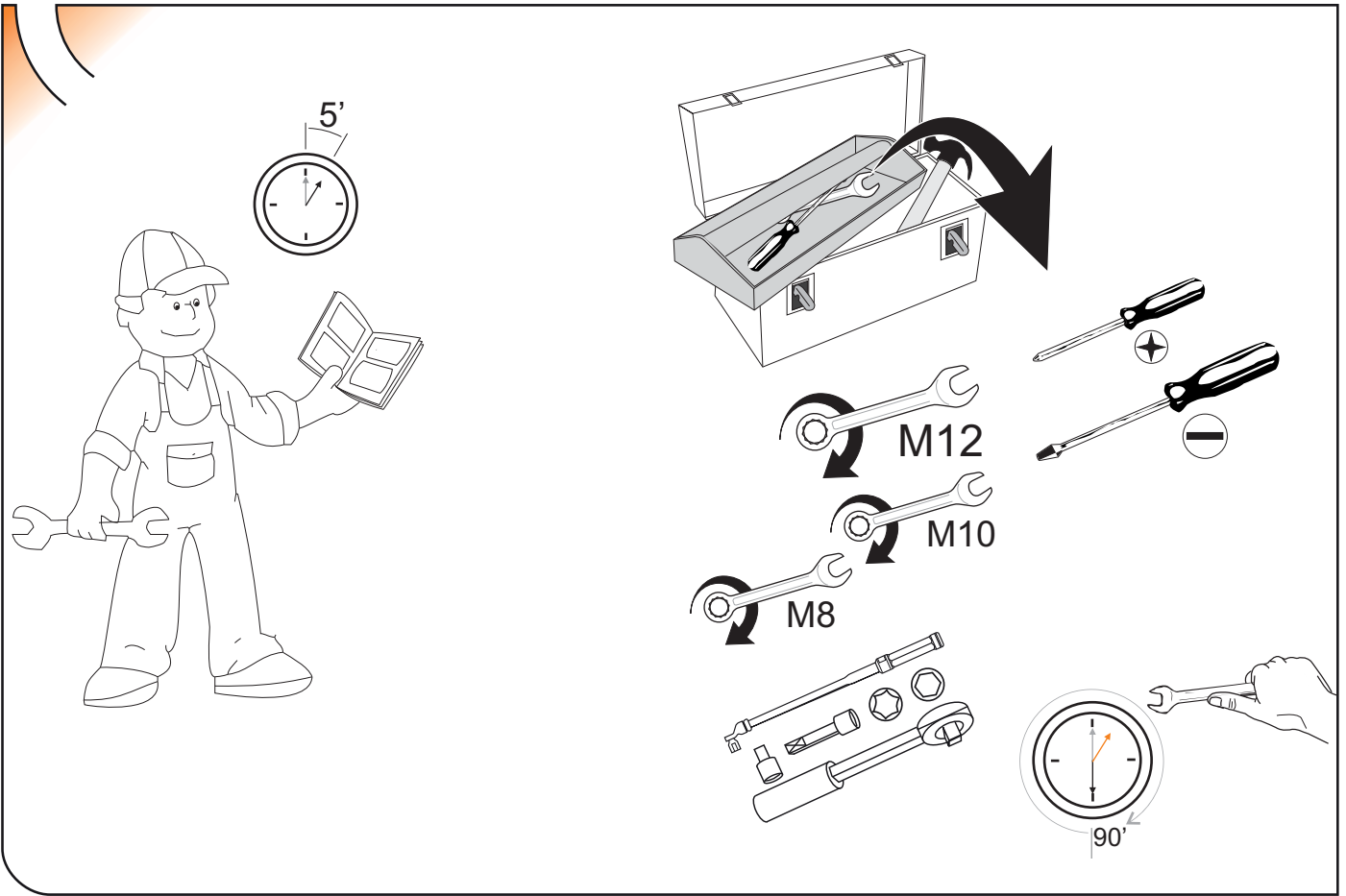

2

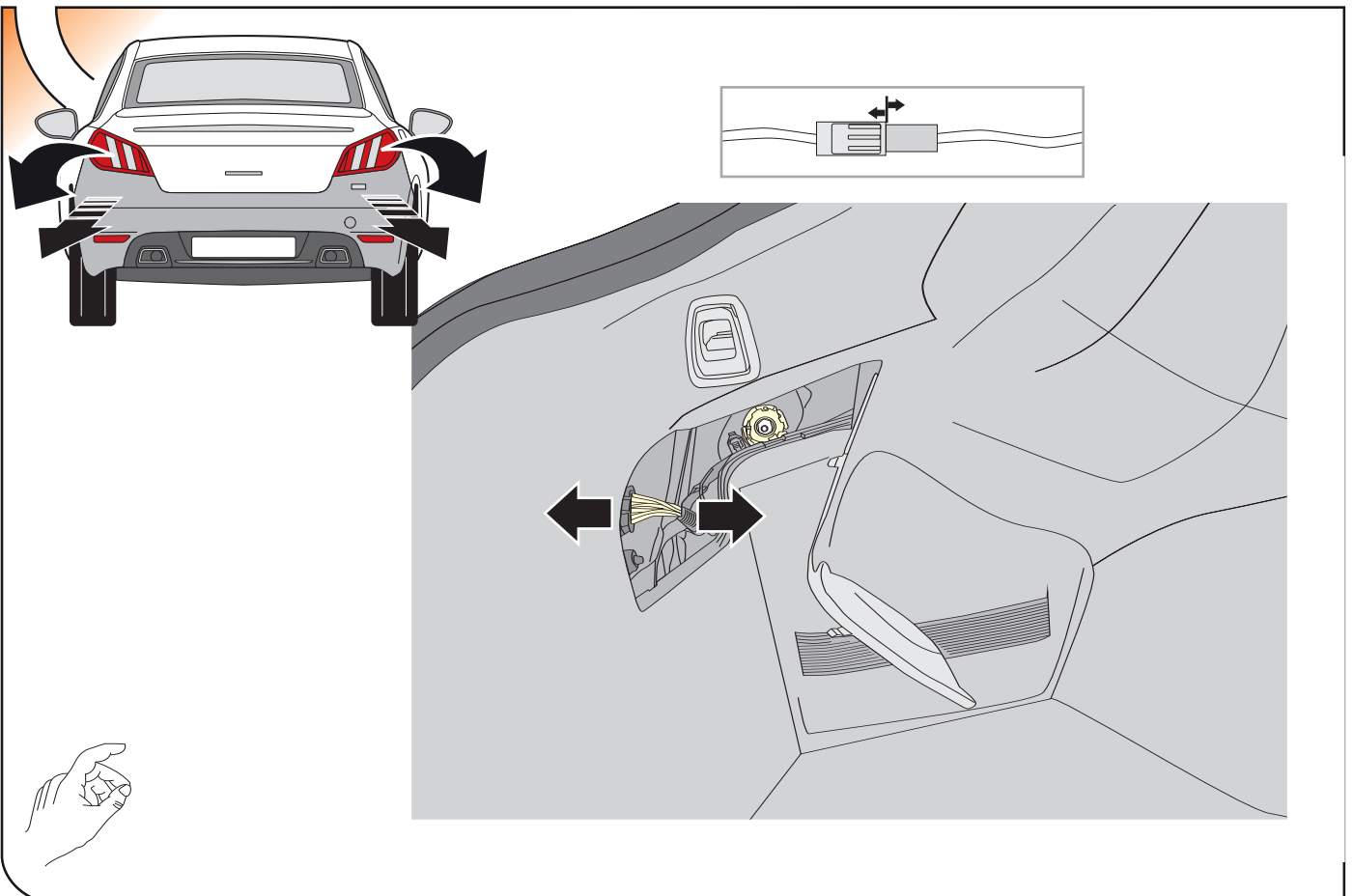

3

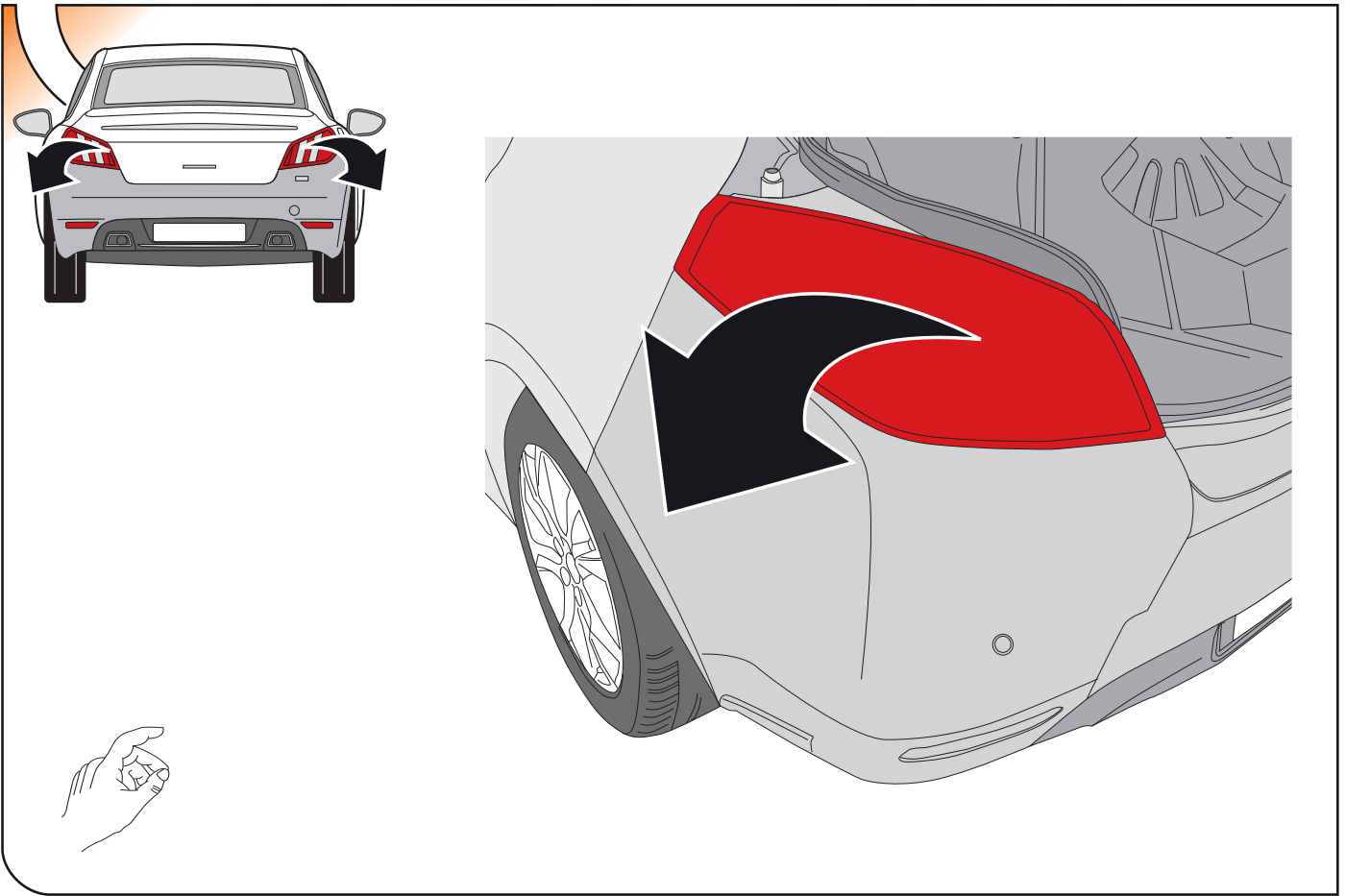

4

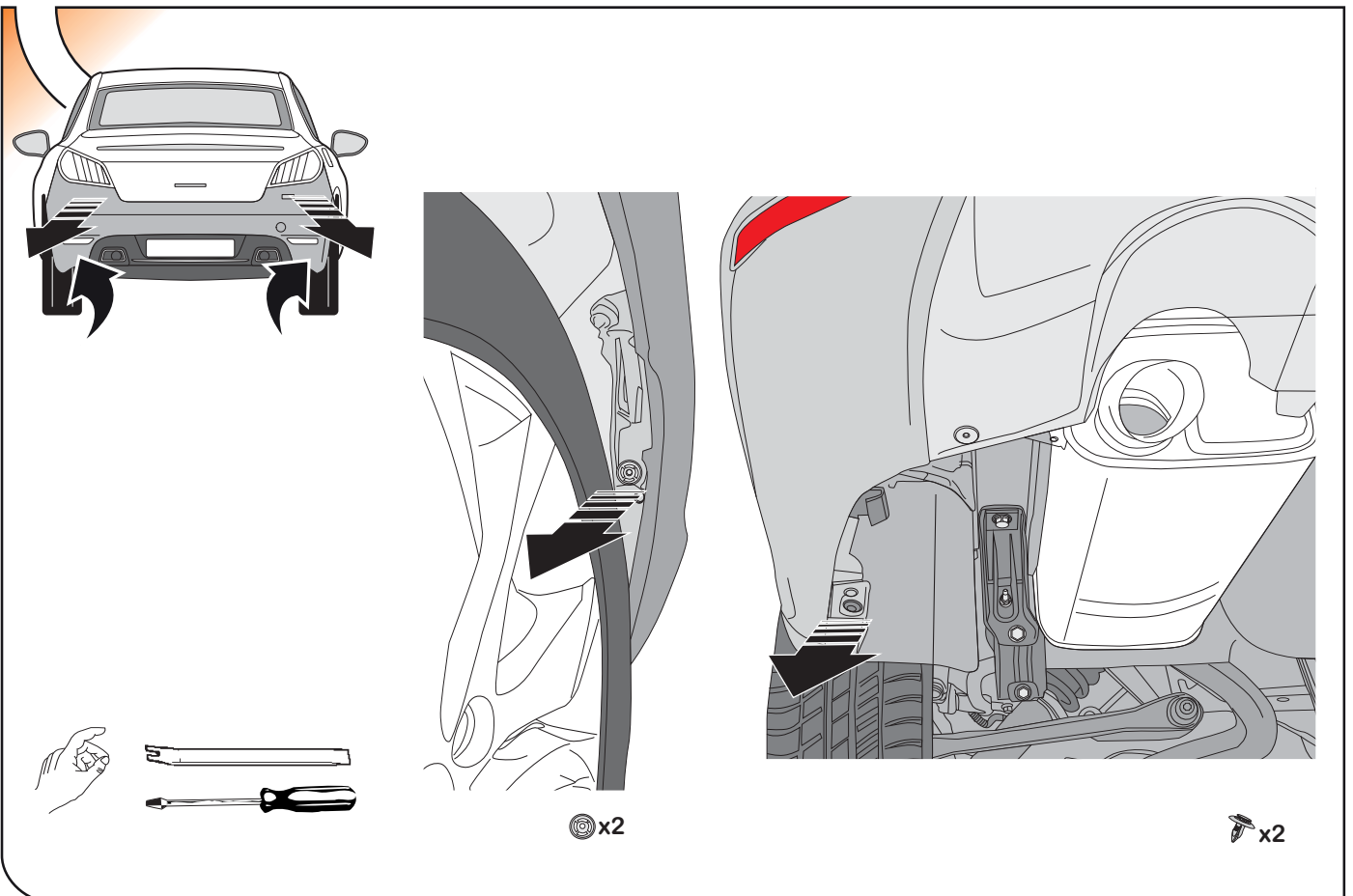

5

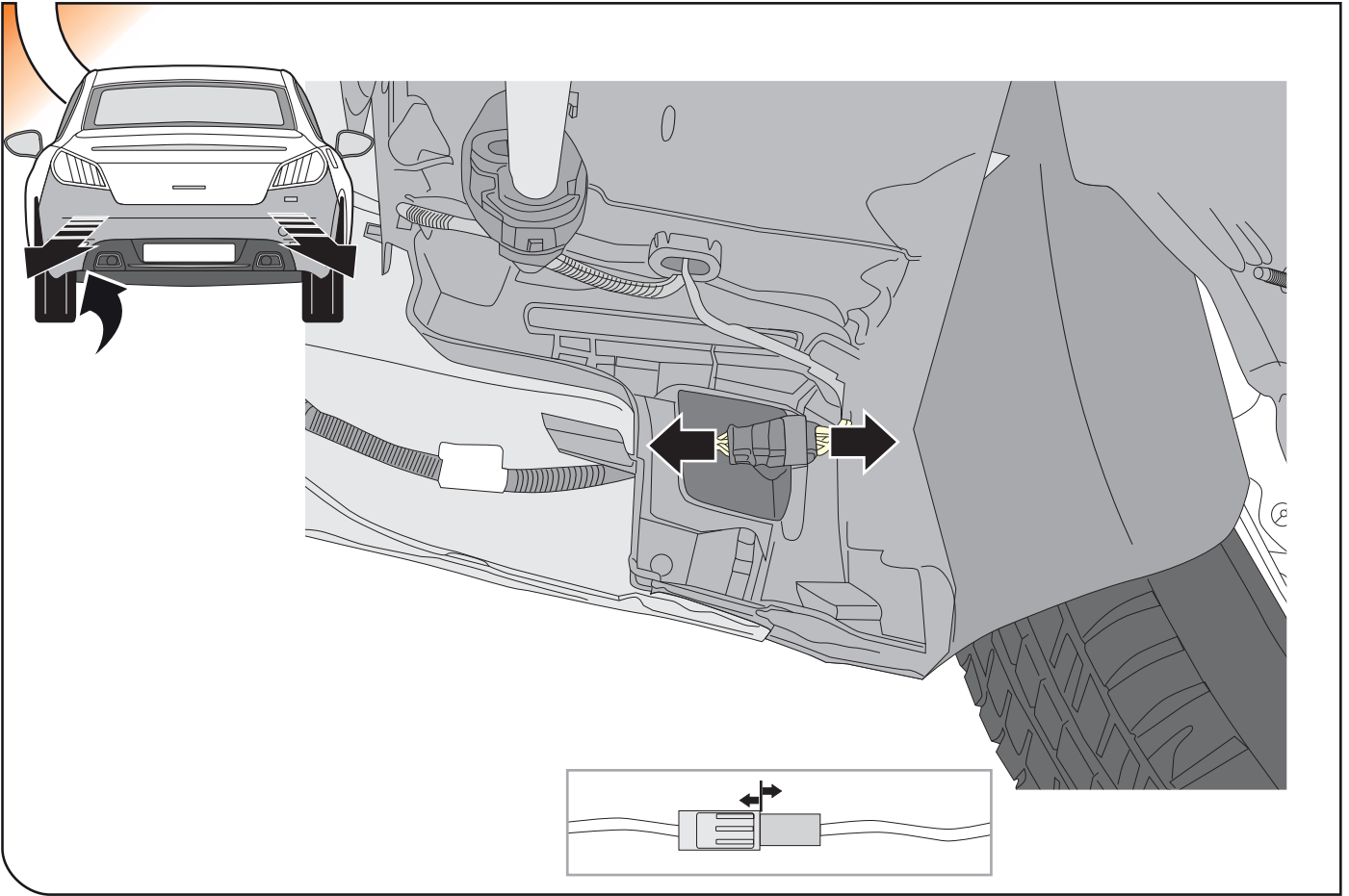

6

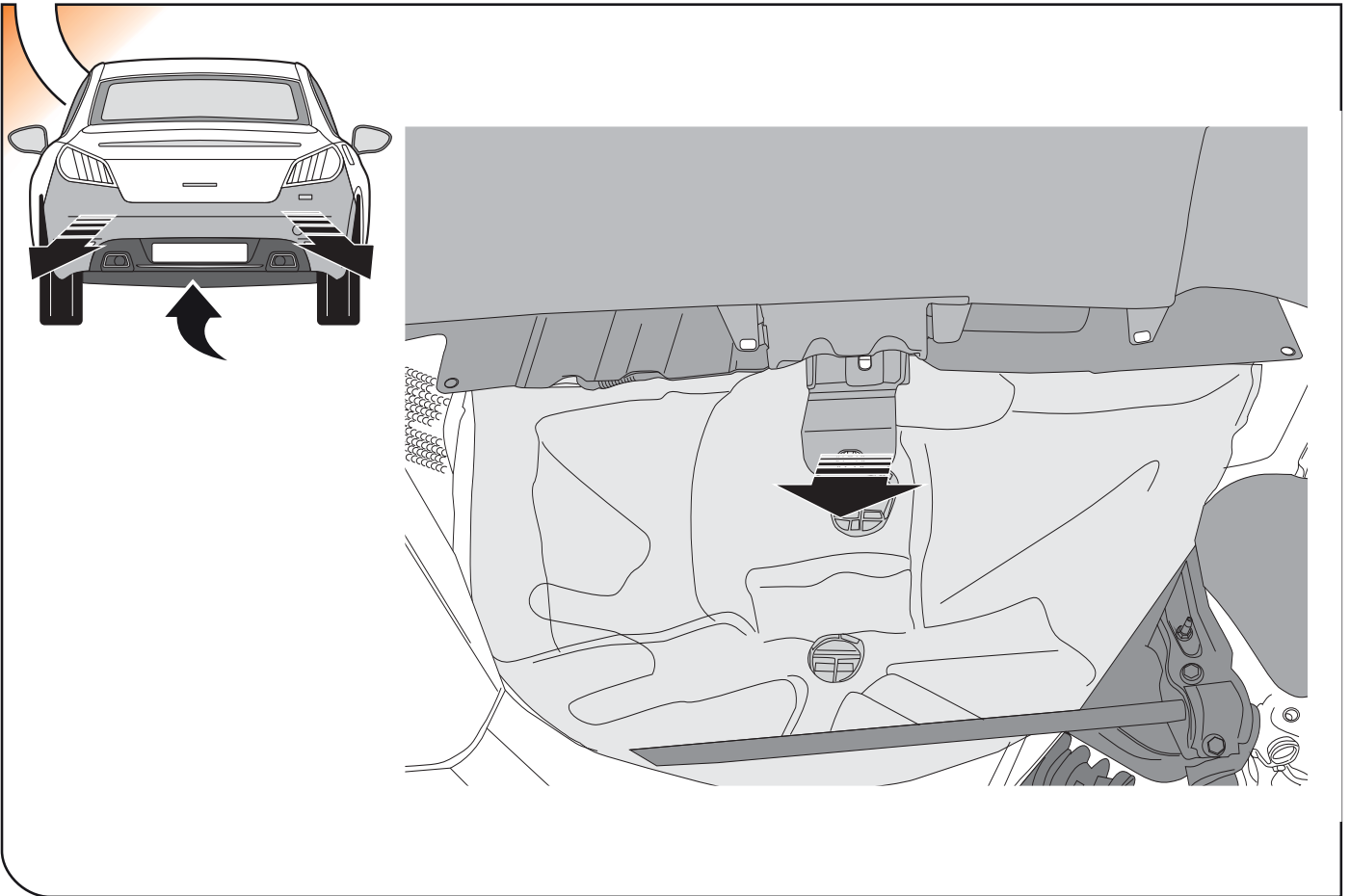

7

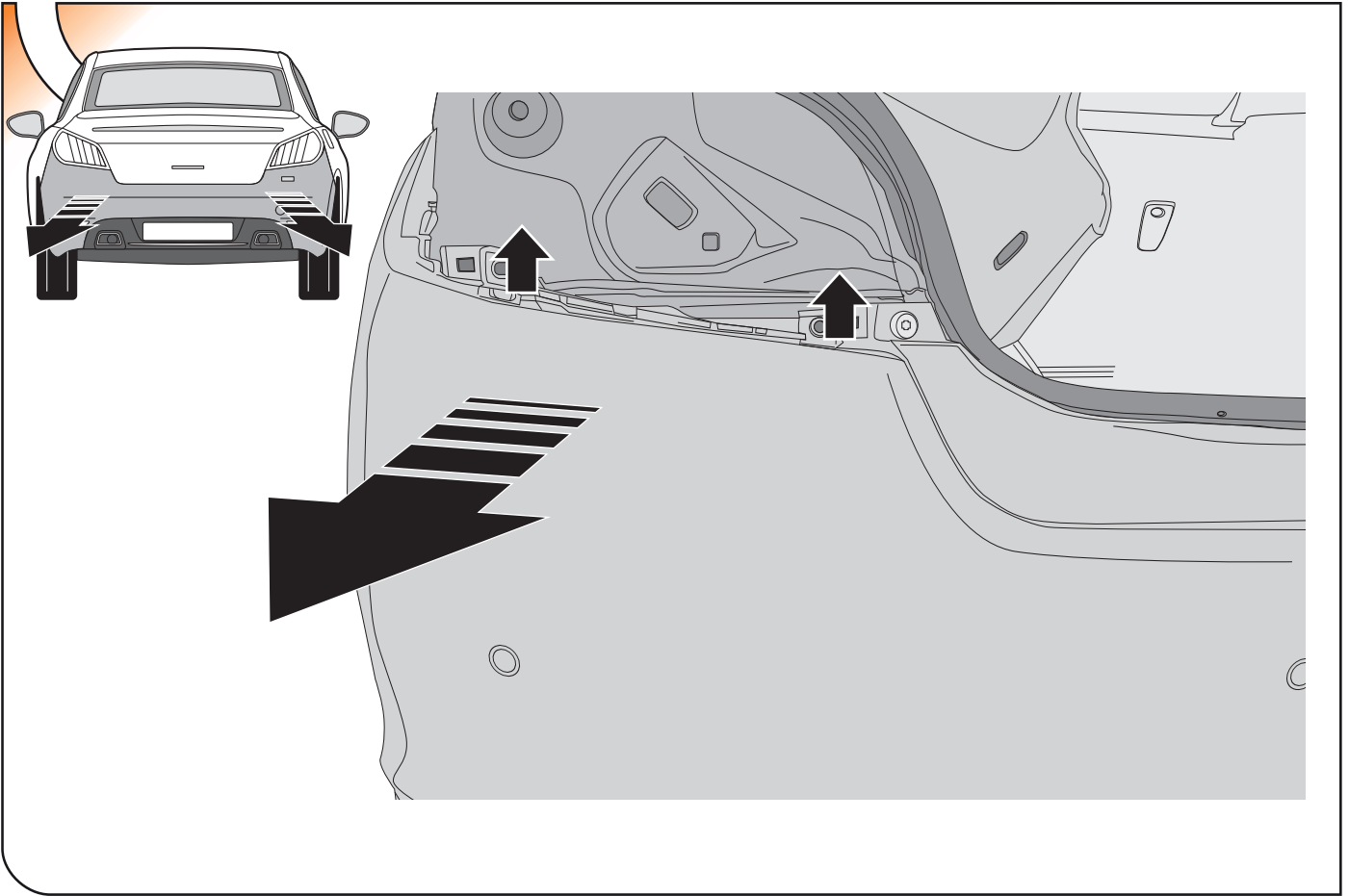

8

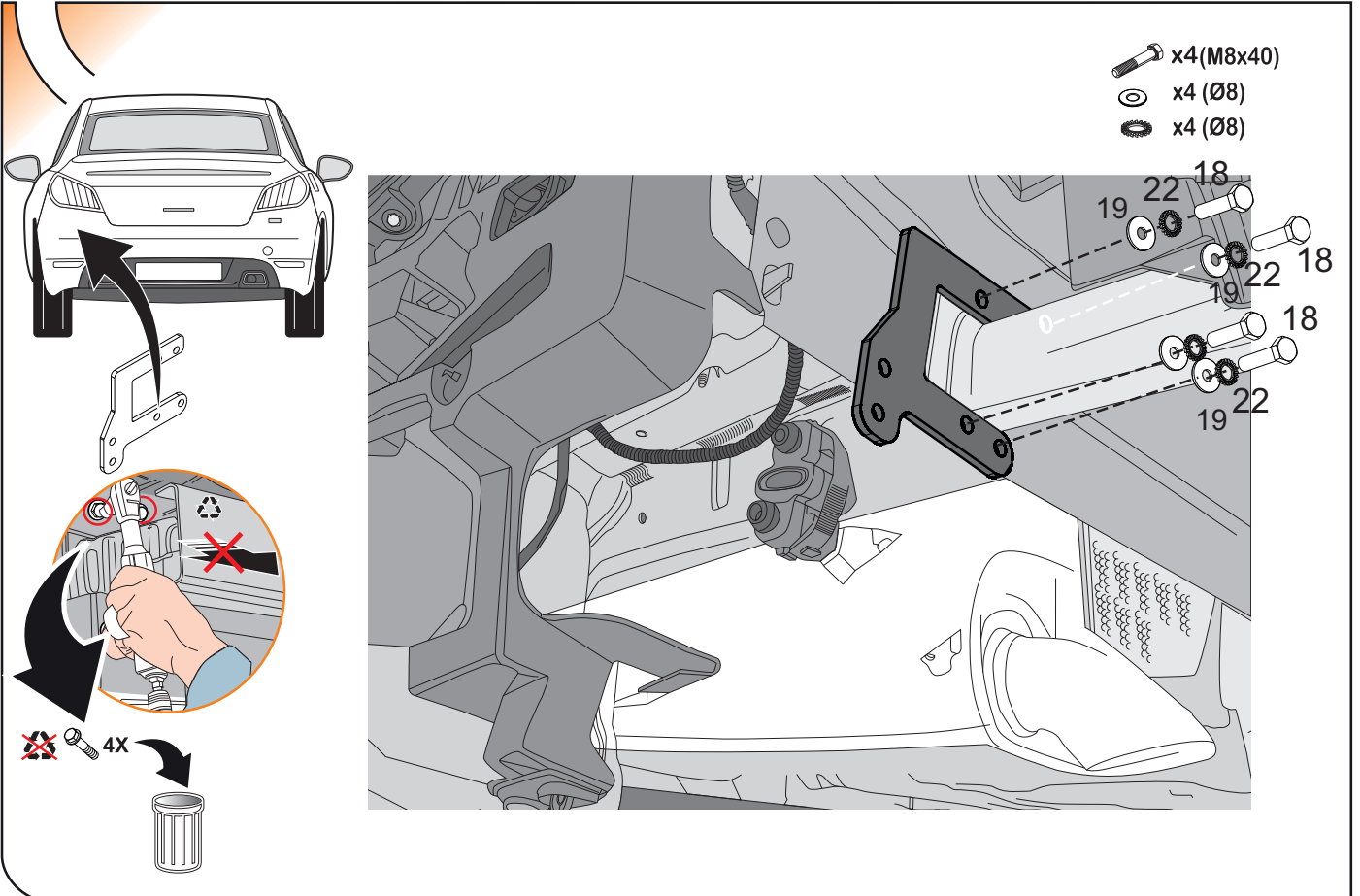

9

4X

- x4 (M8x40)
- x4 (Ø8)
- x4 (Ø8)

10





PEUGEOT 407  
CITROEN C5'08

PEUGEOT 508 2011

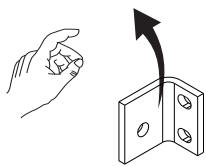
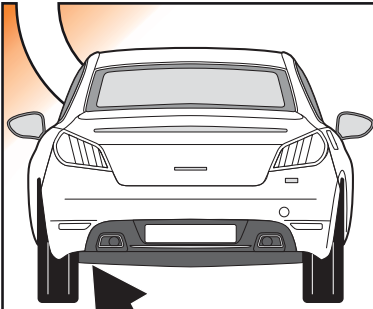
PEUGEOT 508 2011

11





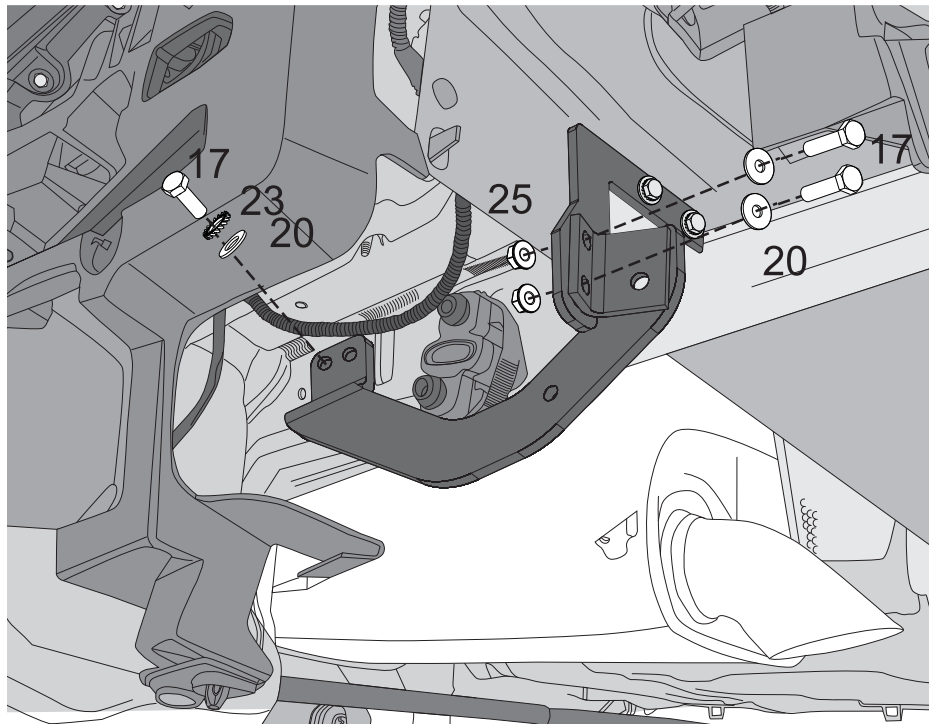

-  x3 (M10x35)
-  x3 (Ø10)
-  x1 (Ø10)
-  x2 (M10)

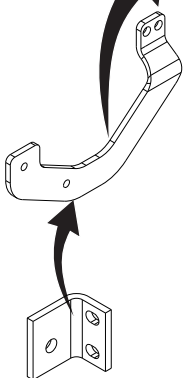
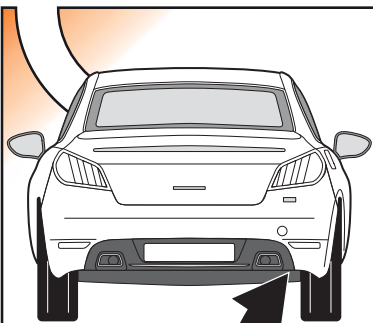

12





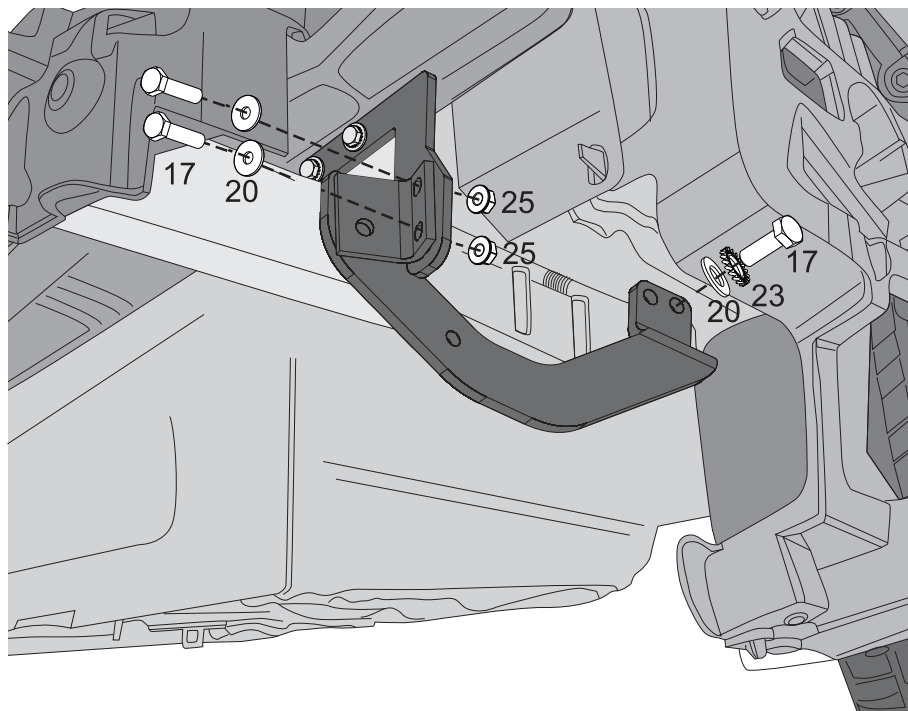

-  x3 (M10x35)
-  x3 (Ø10)
-  x1 (Ø10)
-  x2 (M10)

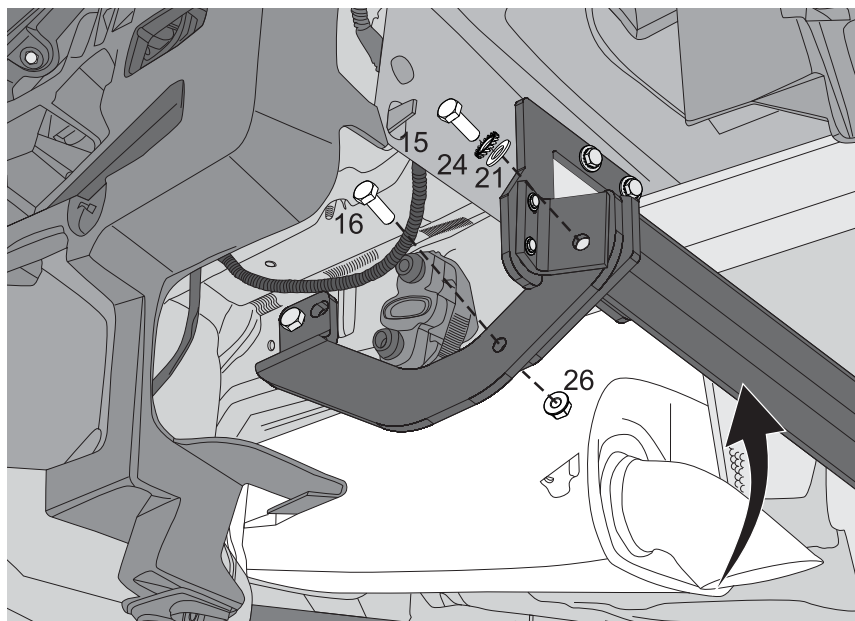
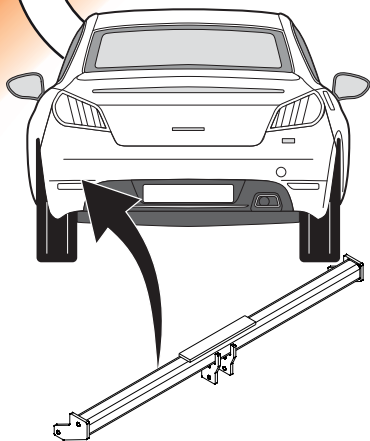

13





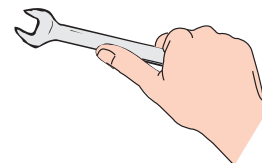

-  x1(M12x50)
-  x1(M12x40)
-  x1 (Ø12)
-  x1 (Ø12)
-  x1 ( M12)

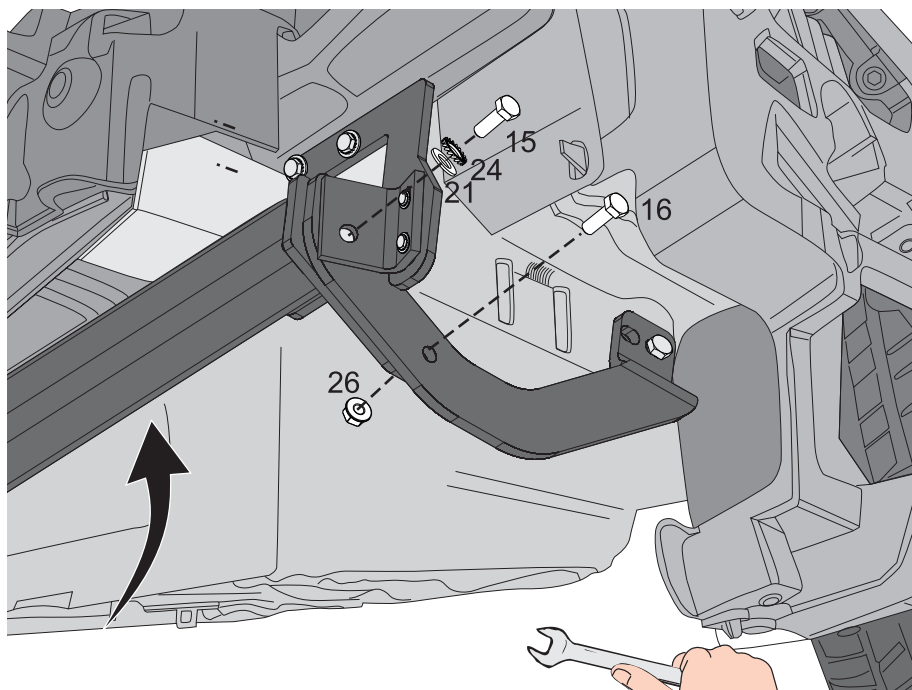
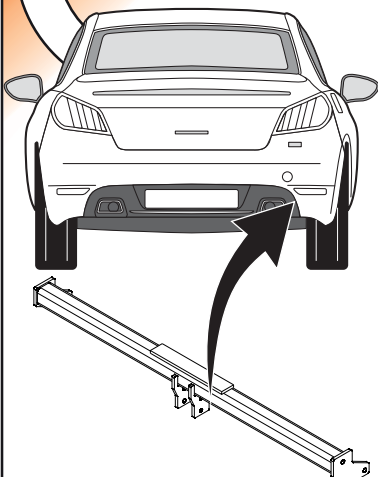



14



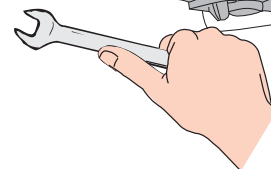

-  x1(M12x50)
-  x1(M12x40)
-  x1 (Ø12)
-  x1 (Ø12)
-  x1 ( M12)



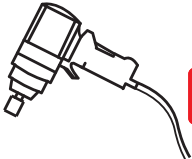

	M8	M10	M12	M14	M16
N/m	20	40	60	105	160





Nm

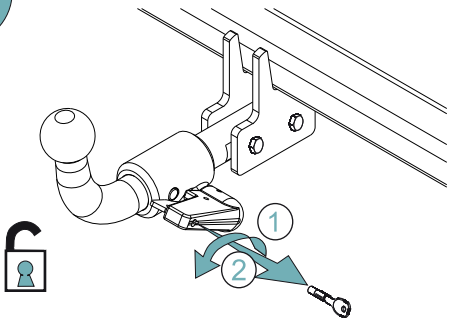

**F** OUT

**1**



**2**

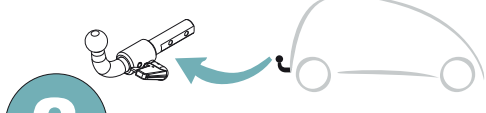
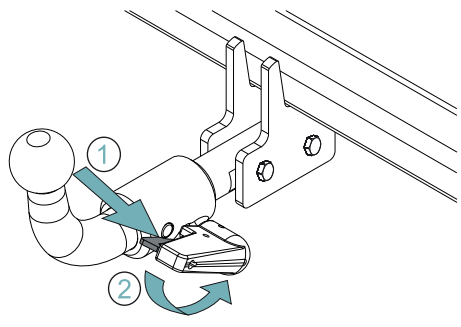

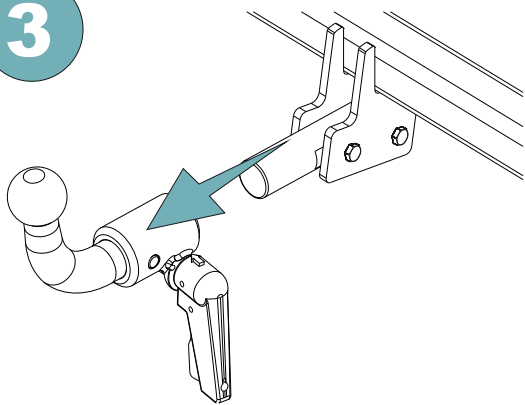

**3**

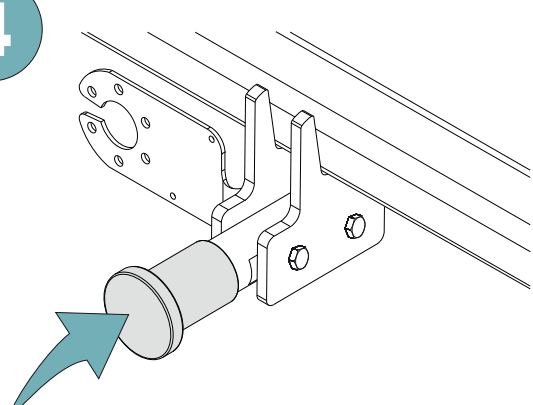

**4**

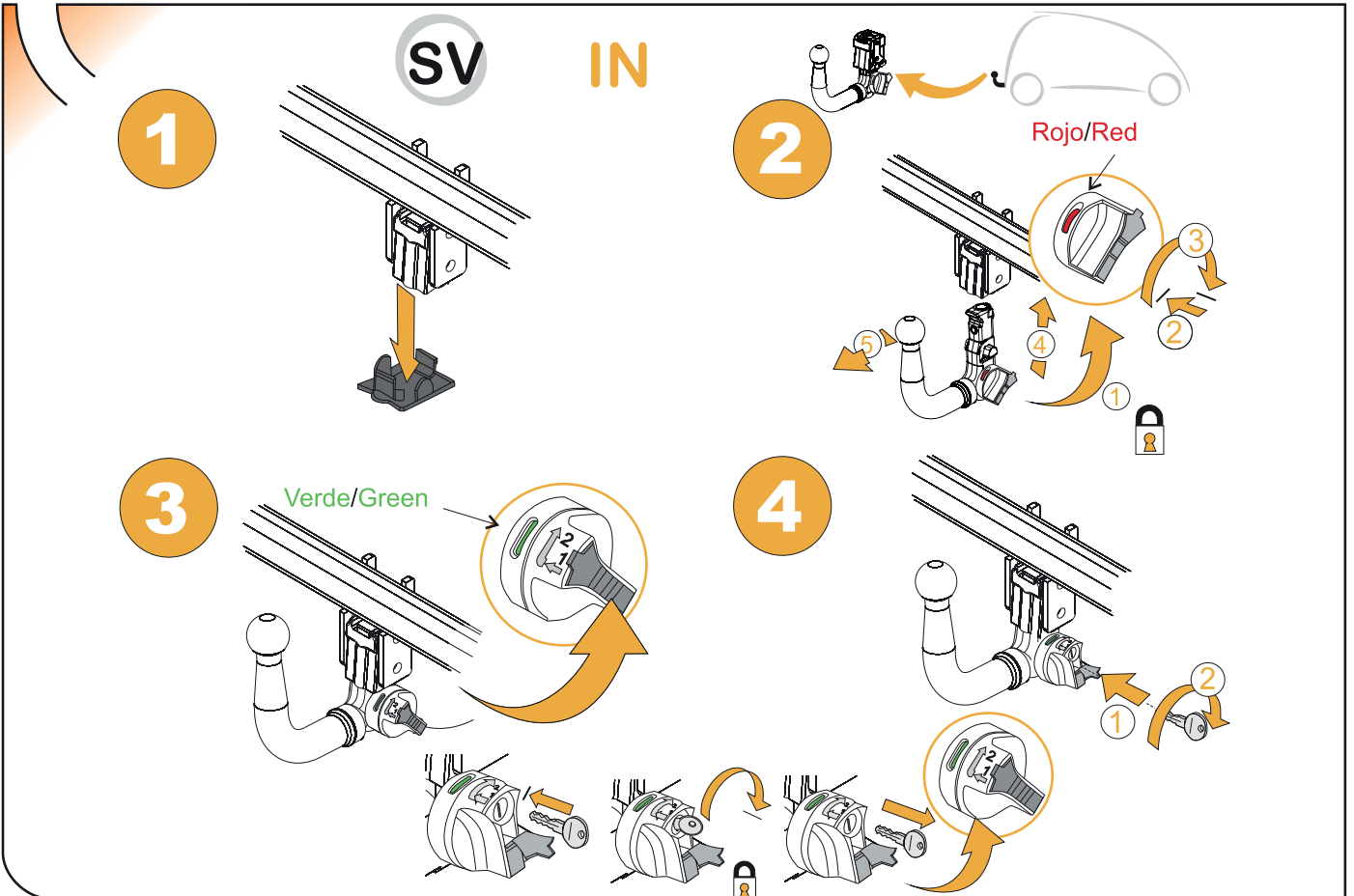
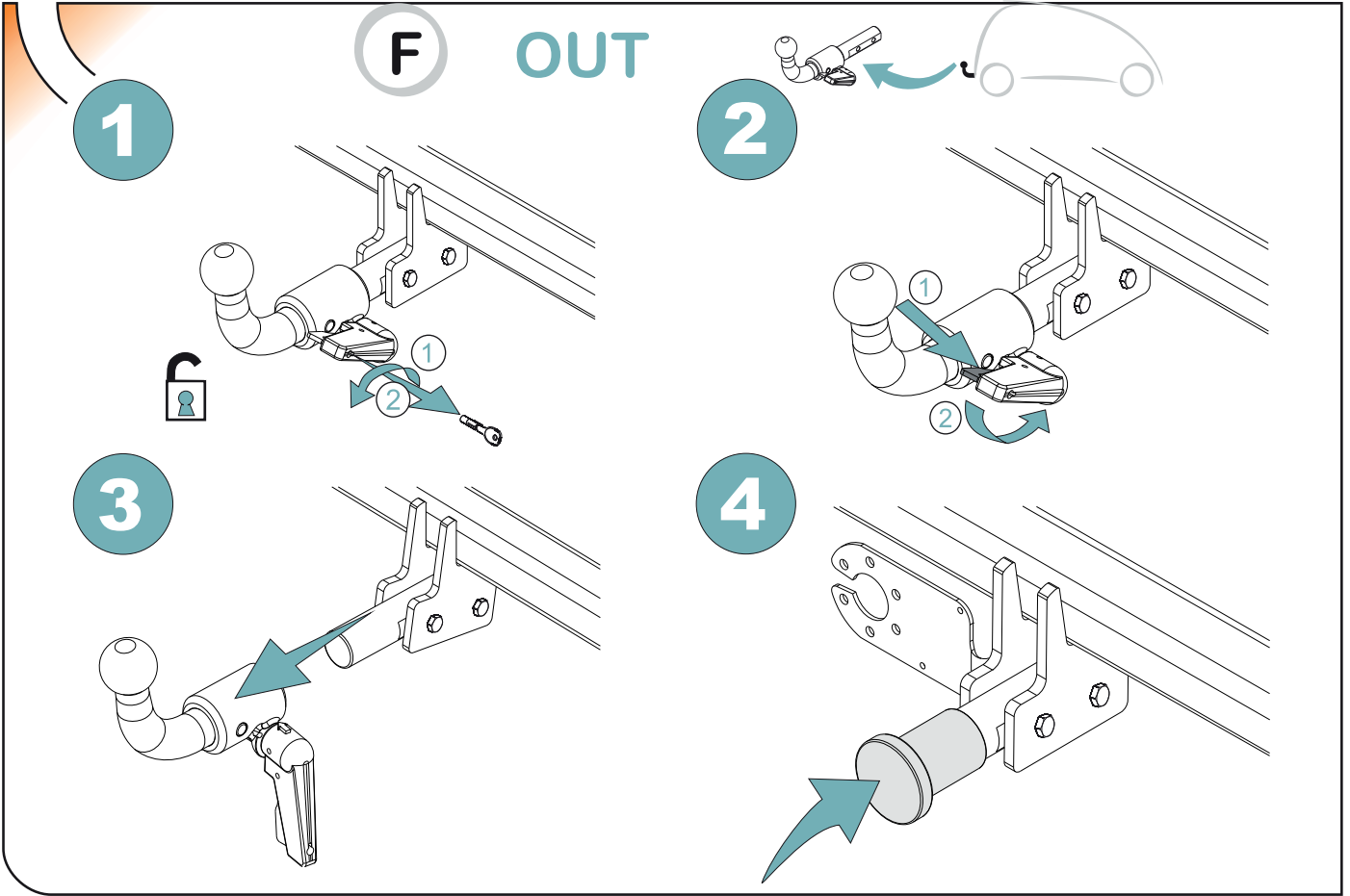



SV

OUT



1

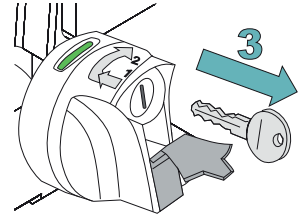
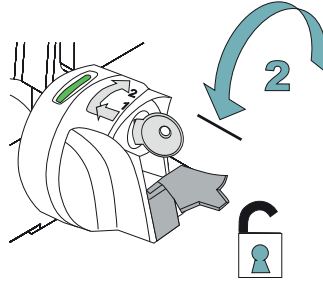
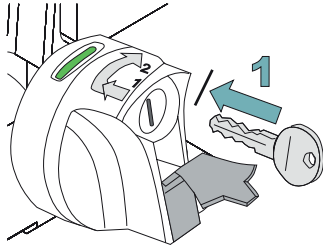

2

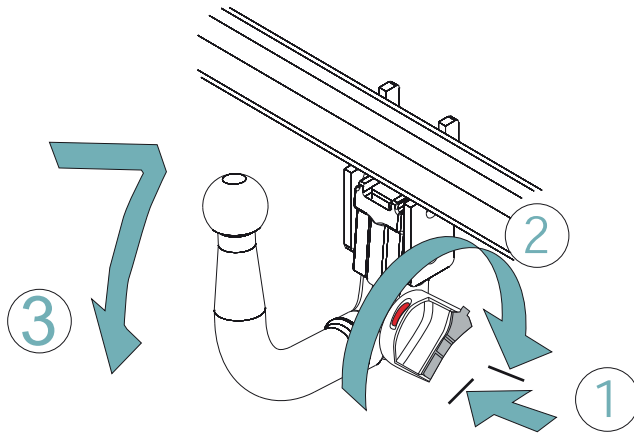



## ANEXO III

### CERTIFICADO DE TALLER

D. \_\_\_\_\_, expresamente autorizado por la \_\_\_\_\_  
domiciliada en \_\_\_\_\_, teléfono \_\_\_\_\_, dedicada  
a la actividad de \_\_\_\_\_ n° de Registro Industrial \_\_\_\_\_ y n° de registro  
especial \_\_\_\_\_.

#### CERTIFICA

Que la mencionada empresa ha realizado la/s Reforma/s y asume la responsabilidad de la ejecución,  
sobre el vehículo marca....., tipo.....  
variante..... denominación comercial .....  
matrícula ..... y n° de bastidor ....., de acuerdo con:

- La normativa vigente en materia de reformas de vehículos.
- Las normas del fabricante del vehículo aplicables a la/s reforma/s llevadas a cabo en dicho vehículo.
- El proyecto descriptivo de la/s reforma/s, adjunto al expediente.

#### OBSERVACIONES: (2)

Tipificada/s con el código de reforma/s.....  
Reforma consiste en:

COLOCACION DE ENGANCHE \_\_\_\_\_

n° de identificación / marca de homologación

Type :

Fecha:

Firma y sello:

Fdo:

(1) En el caso de que la reforma sea efectuada por el fabricante se indicará N/A.

(2) Se debe especificar en este apartado OBSERVACIONES, la identificación de los equipos o sistemas modificados, garantizando que se cumple lo previsto en el artículo 6 del reglamento general de vehículos y, en su caso, en el artículo 5 del R. D. 1457/1986 de 10 de enero, por el que se regula la actividad industrial en talleres de vehículos automóviles, de equipos y sus componentes, modificado por 455/2010 de 16 de abril, por el que se modifica el R. D. 1457/1986 de 10 de enero por el que se regulan la actividad industrial y la prestación.

**ES**

1



2

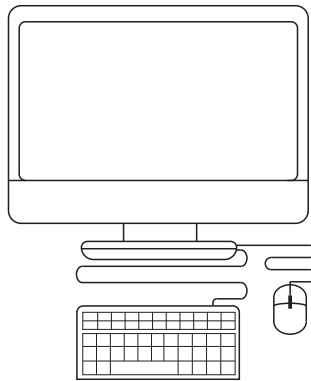

3



**IT**

1

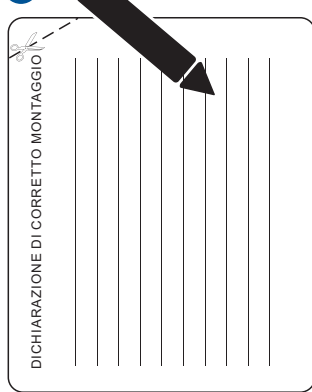

2

